



Lifting power for the future

Truck cranes for
forestry transport and recycling

Cranab®  **Slagkraft®**

FASSI GROUP

The power of Cranab.

Cranab is a world-leading manufacturer of cranes, grapples and related equipment. Ever since the 1960s, we have been driven by our passion for quality, development and the constant desire to improve our customers' everyday lives.

Our long and substantial experience of the development, construction and sales of cranes guarantees quality and a long-term perspective. Each of our cranes is manufactured with precision and is tested in the tough Nordic climate to suit professional users the world over.

Our range of truck cranes has been specifically developed for timber transportation and recycling. We have focused our development on the driver's environment, driving characteristics, performance and quality. Together with our proprietary range of grapples, control system and wide range of options, the cranes form an effective overall solution for each truck on which they have been mounted. All for a better working day.

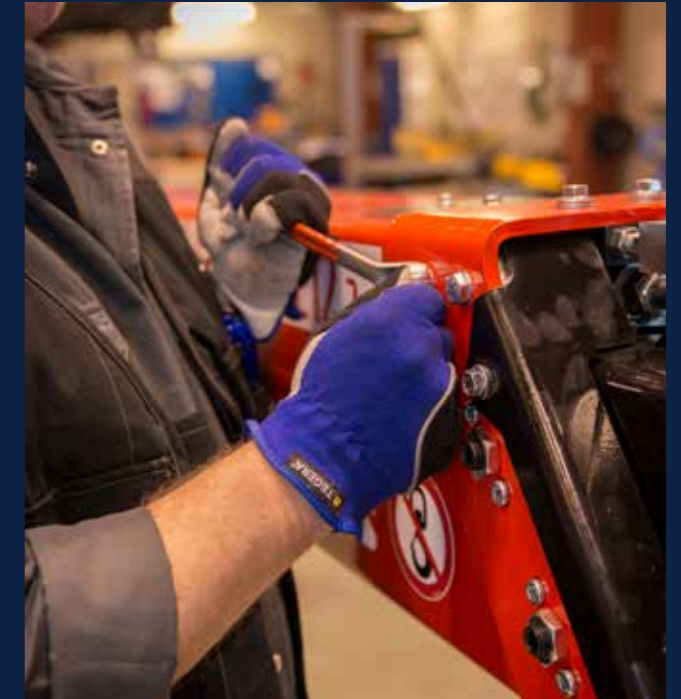

A new generation of truck cranes

Our cranes for timber transportation and recycling are specially produced for trucks and consist of modern, tried-and-tested technologies and world-class hydraulics.

Our truck cranes perform equally well in the forest as they do in industrial areas, and they move just as gracefully in urban environments as in the countryside. The cranes are able to handle everything from timber and scrap to most forms of material handling easily. Irrespective of the task involved, the work is carried out with great precision and a high degree of performance.

The reach of the truck cranes makes Cranab one of the market leaders in its class. Their ample reach significantly streamlines both loading and unloading. They are robust, versatile and lightweight cranes, yet they meet the highest demands of both safety and environment. Their development has focused on quality, operational reliability and service-friendliness.



Adapted for efficient timber handling

Cranab's origins are to make cranes for professional forestry. Our cranes for harvesters and forwarders have long been recognised and popular around the world. We already introduced our very first crane programme for trucks in the 1990s.

The new generation of timber truck cranes from Cranab are therefore based on the best of both worlds and combine proven technology, performance, smart solutions and an understanding of the user's needs.



”

The advantage of the Z-crane is that it's more versatile when unloading and gives a better load height.

Jim Olofsson
Stellan Olofssons Åkeri



MAKE THE RIGHT CHOICE AT ONCE

Contact us or a dealer for personal service when choosing your equipment.

You can find your nearest dealer at www.cranab.se

CRANES

| FORESTRY TRANSPORT

For demanding users

Cranab's truck cranes for timber transport are adapted and optimised for every operation. The cranes are available in both Z-design and L-design as well as several different reaches.

The cranes are made for the demanding user. Our reliable cranes are aimed at professional operators who want to work quickly and safely with efficient loading and unloading cycles. They are suitable for anyone who is in need of a strong and robust, low-weight crane with high performance, well-thought-out geometry and low power loss.

Cranab cranes are available with flexible operator environments. We offer open operator positions with various placements, such as operator's position with adjustable canopy. For those looking for the very best comfort and weather protection, we offer one of the best cabs on the market. We can also offer several control system solutions to meet each user's needs.



OUR CRANES



TL12 • Robust L-design cranes available in different alternative reaches. Being able to lay the crane on top of the load makes for efficient work.



TZ12 • Versatile and quickly extendable Z-design cranes available in both single and double-action telescopic versions. Available from compact 7.7 metres to long 10.5 metres.



TZ18 • Our most powerful crane for the most demanding tasks. The TZ18 is a strong crane that is big enough to handle the largest and heaviest logs.

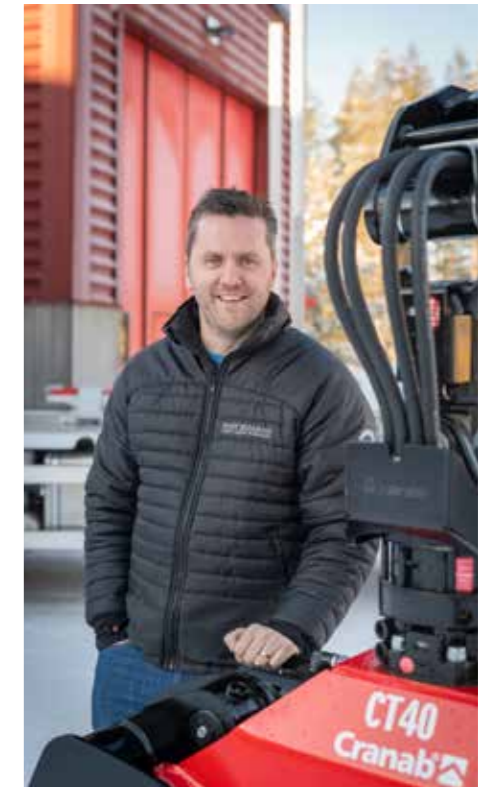

”

The crane has smooth and fine movements, and is strong throughout its range.

Daniel Fjärsmans
Insjöns timmertransporter AB



FOCUS ON DRIVER ENVIRONMENT

Good to know...

...we offer open operator's positions with various placements, weather protection and one of the best cabs on the market.

More about the operator's position can be found on page 22.



TL12

L-design truck cranes

Cranab's L-design truck crane always puts you one step ahead: It is powerful, versatile and flexible, service-friendly and safe.

DEEP DOWN POWER

Each TL crane is equipped with torque link, making the lifting force more even over the entire working area. Like all Cranab truck cranes, internal pipe and hose routing is standard.

EASY TO LOAD

The TL crane is practical in its design and is offered with several different reaches. Loading is really efficient with the longest reach. The operator can reach everywhere without having to reposition the truck or drive too close to the landing. The crane easily be placed up on the load for fast transport to the next site.

The crane can be provided with different types of operator's position, equipped with different forms of lighting as well as a market-leading wireless weighing system.

ULTRASONIC CONTROL

For extra safety, Cranab performs a mandatory ultrasound inspection of all critical welding joints. Sitting in the operator's position must be completely safe. Therefore, we have introduced a requirement into the manufacturing process that the area around the crane post and mountings shall be uncompromisingly durable. We can inspect the joint welds with ultrasound to ensure that they meet our high demands.

INTERNAL ROUTING

Every hose and pipe is routed internally and protected throughout the arm system.

TORQUE LINK

Link between the post and main boom for increased power in all situations. The torque link means uniform movement and speed right across the working range, giving good operating characteristics.

SLEWING MOTOR

The crane's slewing motor with double slewing systems gives a 425 degree slewing angle. This means that the crane has a very good slewing ability in several directions. The geometry of the slewing motor and several components are taken from the forwarder crane technology.

PINS OF THE HIGHEST CLASS

The pins are of a good size. They are nitrocarburised for improved durability and maximum corrosion protection. Low friction means reduced wear on all bushings.

SLIDE BLOCKS

Slide blocks adjustable from the outside of the outer boom. Adjustments can easily be made from outside using a hex key to make the crane steady and stable.

DOUBLE TELESCOPE

Cranab is one of few manufacturers able to offer a full 10 metre reach. The TL cranes are available with both single and double telescoping for maximum agility and the best reach.



DID YOU KNOW THAT...

... A three-point yoke makes a difference

Cranab's truck cranes are equipped with a three-point yoke that sits on the stabiliser beam. The three-point yoke counteracts torsion in the truck chassis.

... Smooth braking crane

The cranes are equipped with end-position damping in the slewing motor. This enables smooth braking at each end position, which gives reduced wear and good operational characteristics.



LEADING REACH

FAR REACHING

Cranab is one of few manufacturers able to offer a full 10 metre reach. The TL12.1 is a single telescopic crane reaching 8.3 metres while the TL12.2 is a double telescopic crane that reaches the farthest, 10 metres.



TZ12 / TZ18

Z-design truck cranes

With Cranab's Z-cranes, you can quickly become productive right from the start. The range of cranes includes several designs and reaches. TZ12 is available in four designs and covers the needs of most users. If even more power and strength is required, there is the strong TZ18.

UP AND RUNNING IN NO TIME

Our Z-cranes are quickly extendable and retractable. World-class hydraulics give responsive, strong cranes and leading operational characteristics. With the carefully adapted geometry, as well as the crane's other components and solutions, the foundation is laid for a very efficient timber handling.

OPTIMISES LOADING SPACE

Thanks to its compact design and the Z-crane's unique parking position (see figure on pages 8-9), you are able to take a maximum load every time. The advantage of a Z crane is that it can be folded at the back of the

truck. With the Z-crane, it is therefore possible to put a full load on the truck without losing load capacity.

ULTRASONIC CONTROL

The cranes undergo meticulous manufacture and all welding is essentially robotic. We have introduced obligatory ultrasound inspection of critical welded joints. Sitting in the operator's position must be completely safe. Therefore, we have introduced a requirement into the manufacturing process that the area around the crane post and mountings shall be uncompromisingly durable. We can inspect the joint welds with ultrasound to ensure that they meet our high demands.

INTERNAL ROUTING

Every hose and pipe is routed internally and protected throughout the arm system.

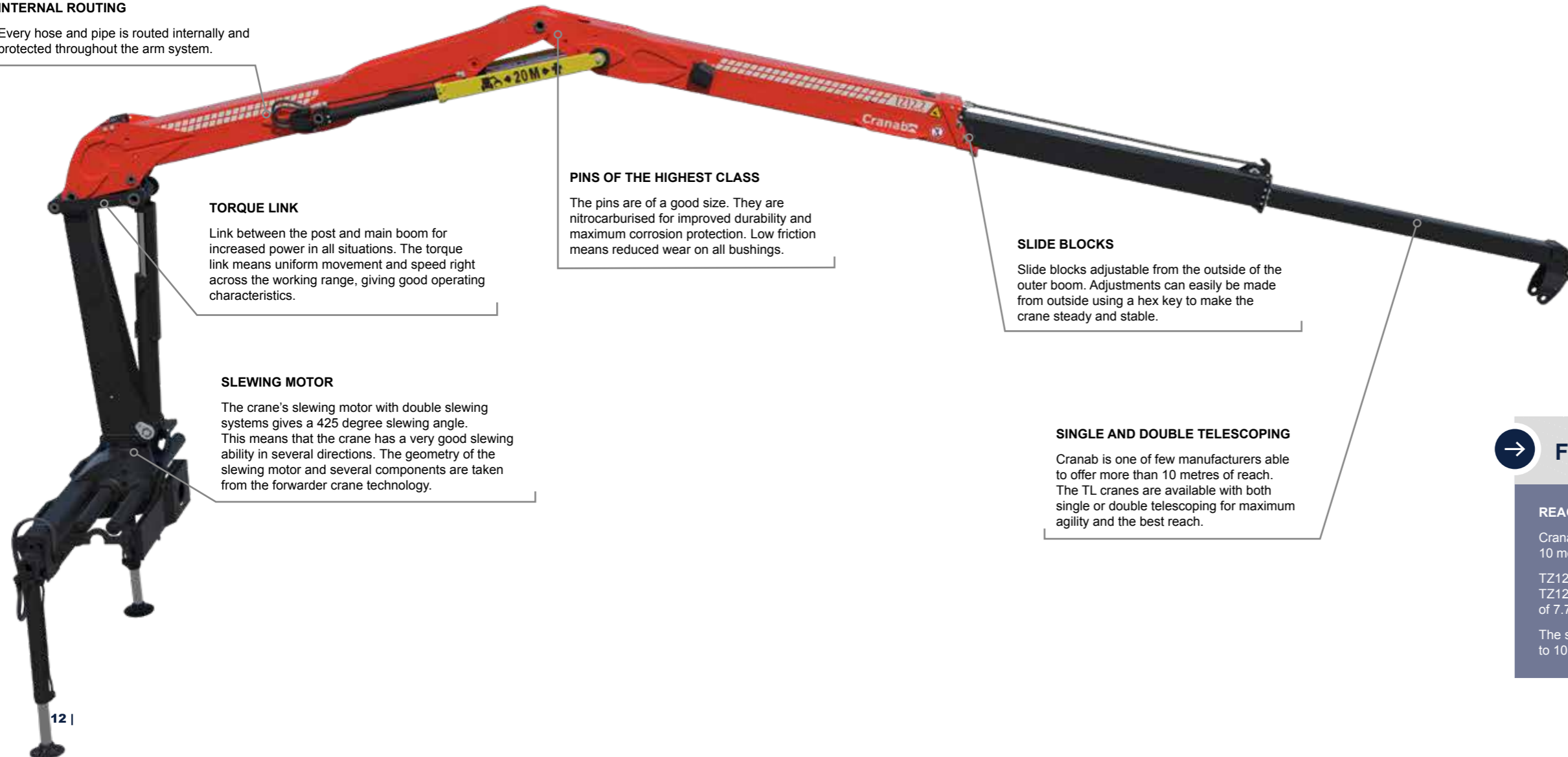

TORQUE LINK

Link between the post and main boom for increased power in all situations. The torque link means uniform movement and speed right across the working range, giving good operating characteristics.

SLEWING MOTOR

The crane's slewing motor with double slewing systems gives a 425 degree slewing angle. This means that the crane has a very good slewing ability in several directions. The geometry of the slewing motor and several components are taken from the forwarder crane technology.

PINS OF THE HIGHEST CLASS

The pins are of a good size. They are nitrocarburised for improved durability and maximum corrosion protection. Low friction means reduced wear on all bushings.

SLIDE BLOCKS

Slide blocks adjustable from the outside of the outer boom. Adjustments can easily be made from outside using a hex key to make the crane steady and stable.

SINGLE AND DOUBLE TELESCOPING

Cranab is one of few manufacturers able to offer more than 10 metres of reach. The TL cranes are available with both single or double telescoping for maximum agility and the best reach.

→ DID YOU KNOW THAT...

... The telescopic effect is unique

Unique to the TZ12 is Cranab's design that means the crane can reach farther than other cranes on the market. The outer boom is completely straight and allows for longer booms. This gives it a much better telescoping effect and increases reach.

... TZ18 is the strongest of all

TZ18 crane model is designed to be used for the toughest of tasks. The crane is robust, well classified and used for demanding tasks. TZ18 can manage thicker timber and heavier materials, and it takes over where the 12 ton/metre TZ12 crane is too small.

→ FLEXIBLE RANGE

REACHES UP TO 10.5 METRES

Cranab is one of few manufacturers able to offer more than 10 metres of reach. The reach of this range of cranes is large.

TZ12.1 is a single telescopic crane reaching 8.3 metres. TZ12.2 is a double telescopic crane available with reaches of 7.7 metres, 9.3 metres and a whopping 10.5 metres.

The strong TZ18 is available with different reaches up to 10.2 metres.

GRAPPLES

Bespoke timber grapples for truck operation

Cranab's CT grapple series has been developed and fully adapted for working with truck cranes. Together with the TL/TZ range of cranes, these grapples form a complete system that is optimised one after the other and carefully tested for its application.

Cranab has been manufacturing grapples for forestry machines for more than 50 years. With this experience behind us and close dialogue with professional users, we have developed a customised range for trucks.

CORRECTLY DIMENSIONED

The development work has placed major emphasis on handling and the weight of the grapples. The hunt for unnecessary weight is constantly in focus in truck transports. When designing the grapples, we have focused on weight optimisation and dimensioning without sacrificing performance, reliability and driveability. Thanks to careful work and smart choices, we have been able to reduce the material thickness of the grapples and make them narrower than others.

LOADING AND UNLOADING

The grapples easily penetrate the stacks of timber and have excellent roll-in characteristics. They are very easy to work with. Grapples used on forwarders are designed for continuous operation and demanding work. A grapple on a mobile crane operates on a completely different frequency. Truck grapples are used in the loading and unloading of timber stacks and are not usually seen digging down into the ground, the way a grapple on a forwarder does. Grapple requirements vary and truck grapples are optimised for their areas of use.

CT35



Small, versatile and compact

The CT35 is the smallest in the range of grapples. It is a very compact and agile grapple that does the job just as well as the larger models but on a smaller scale.

The grapple is suitable for all applications where the truck and crane are smaller and there is no need to take large volumes in each grab.

CT40



Grapple that suits most

CT40 is our standard size, the grapple model that suits the vast majority of users and truck cranes.

This grapple combines performance, weight and lifting capacity in a very good way. Like its siblings, the CT40 has very good characteristics to enable logs to roll in, high penetration capacity and large opening width.

CT50



Handles the toughest jobs

CT50 is unique in the truck range and is designed to maximise each grab and work as quickly as possible. It can pick up large volumes at a time.

The grapple size is popular throughout Europe and the CT50 meets the needs of the most demanding users and the toughest jobs.

Strong and flexible cranes for recycling.

Material handling and recycling is an important industrial sector throughout Europe and part of the efforts needed to contribute to a globally sustainable society. Cranab's RZ program is aimed at professional users in the field of recycling and material handling.

The cranes are reliable, efficient and based on well-proven technology. They have been fully adapted for their area of use in recycling and material handling. The RZ cranes have inherited several good qualities from Cranab's world-renowned crane range for forwarders. They are also closely related to Cranab's TZ range for timber trucks.

The cranes feature protected hose routing, world-class hydraulics and are customised with leading stability monitoring and electronics.



→ **MAKE THE RIGHT CHOICE AT ONCE**

Contact us or a dealer for personal service when choosing your equipment.

You can find your nearest dealer at www.cranab.se

CRANES | RECYCLING

For efficient material handling and recycling

Cranab's RZ cranes are specially designed for professional use in recycling. The philosophy behind them is that they should be responsive, easy to operate and very reliable. The cranes are fully adapted to today's modern Euro 6 trucks.

RZ cranes are designed for compact and safe mounting behind a truck cab. From there, the operator gets the very best visibility and the crane the best radius of action. Cranab's RZ cranes have a 425 degree slewing angle and are double telescopic, which means that each crane can make maximum use of the working area regardless of reach. The operator's position is available in a number of designs and alternative locations for the best comfort and working environment. The crane properties have been adapted for safe work in densely populated environments.

The stabiliser beam is available in a standard width as well as a wider version. It is particularly suitable for recycling applications and in cases where smaller trucks have been equipped with slightly larger cranes. The wide stabiliser beam provides optimal stability and the support legs are easily raised and lowered.

” In the development of our recycling cranes, we have combined the needs of the users and our long experience of crane manufacturing.

Staffan Meijer, Director export sales | Cranab

OUR CRANES



RZ12 • Fast and efficient Z-cranes optimised for handling materials. Compact parking mode, quickly extendable and large slewing angle. Double telescopic is standard and is available from 7.7 to 10.5 metres' reach. The RZ12 is also available as a single telescopic crane with a reach of 8.3 metres.

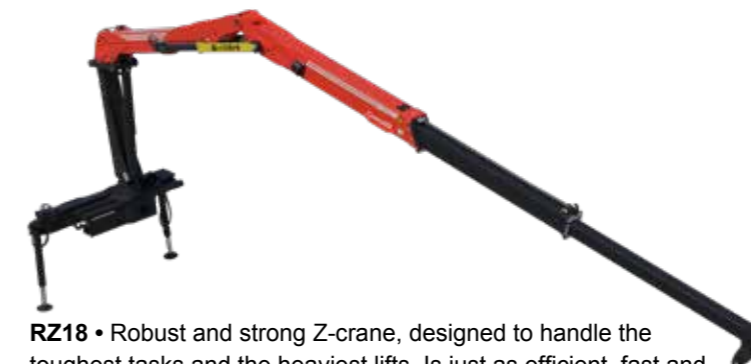

RZ18 • Robust and strong Z-crane, designed to handle the toughest tasks and the heaviest lifts. Is just as efficient, fast and with the same good characteristics as the smaller RZ12 cranes.

→ OPTIONS & FEATURES

Stabiliser beam, control system and own colour scheme.

More possibilities and features can be found on page 24-25





RZ12 / RZ18

Robust cranes for recycling

With Cranab's RZ cranes, every operator quickly becomes productive right from the start. The RZ12 is available in four versions from 7.7 metres to 10.5 metres and covers the needs of most users. If even more power and strength is required, there is the strong giant RZ18.

UP AND RUNNING IN NO TIME

RZ-cranes are quickly extendable and retractable. It takes a short time for the support legs to be extended until the crane is ready for use. World-class hydraulics give responsive, strong cranes and leading operational characteristics. With the carefully adapted geometry, as well as the crane's other components and solutions, the foundation is laid for a very efficient handling of scrap or other materials.

The characteristics of the crane and the possibility of different location of the operator's position mean

that the operator always has a full overview. Remote control is also available as an option.

ULTRASONIC CONTROL

The RZ-cranes undergo meticulous manufacture and welding is essentially robotic. Sitting in the operator's position must be completely safe. Therefore, we have introduced a requirement into the manufacturing process that the area around the crane post and mountings shall be uncompromisingly durable. Joint welds undergo obligatory ultrasound testing to ensure that they meet our high demands.

INTERNAL ROUTING

Every hose and pipe is routed internally and protected throughout the arm system.

TORQUE LINK

Link between the post and main boom for increased power in all situations. The torque link means uniform movement and speed right across the working range, giving good operating characteristics.

PILOT-CONTROLLED CHECK VALVE

Safety system for recycling work. For safe crane operation.

SLEWING MOTOR

The crane's slewing motor with double slewing systems gives a 425 degree slewing angle. This means that the crane has a very good slewing ability in several directions. In connection with the slewing motor is also the crane's slewing sensor.

STABILITY CONTROL

System with sensors for checking stabilising beams, crane arm position and load, plus control unit with software that ensures that the vehicle is stable in all set-up and load variants.

STABILISER BEAM WITH DIFFERENT WIDTHS

A wider stabiliser beam may be preferable in recycling. The stabiliser beam can be equipped with internal hoses and is available in two different maximum widths.

SLIDE BLOCKS

Slide blocks adjustable from the outside of the outer boom. Adjustments are easily made from the outside using an Allen key to make the crane steady and stable.

PINS OF THE HIGHEST CLASS

The pins are of a good size. They are nitrocarburised for improved durability and maximum corrosion protection. Low friction means reduced wear on all bushings.

DOUBLE TELESCOPE

Cranab is one of few manufacturers able to offer more than 10 metres of reach. The RZ cranes are equipped with double telescoping for maximum agility, strength and reach. This also applies to our smallest crane RZ12 7.7. The seven-metre crane is just as robust as its bigger siblings.

→ DID YOU KNOW THAT...

... Our smallest crane is compact in several ways

The RZ12 with 7.7 metres in reach is designed not to drop below the stabiliser beam when it is retracted to park position. This makes it optimal for recycling work and the very latest trucks.

Its compact design makes it particularly suitable for trucks that meet Euro 6 requirements, where space may be limited. The seven-metre crane is just as robust as its bigger siblings and it matches their good performance and capacity. It is only the reach that has been adapted.

→ GETTING WHERE YOU NEED TO GO

REACH UP TO 10.5 METRES

Cranab is one of few manufacturers able to offer more than 10 metres of reach. The reach of this range of cranes is large.

RZ12 is a double telescopic crane available with reaches of 7.7 metres, 9.3 metres and a whopping 10.5 metres. It is also available in a longer version that reaches a full 10.5 metres.

The strong RZ18 has a reach of no less than 10.2 metres.

OPERATOR'S POSITION

No work can be done without an operator and each user's needs are unique. We've taken that into account.

Operating the crane and grapple equipment is part of the operator's everyday life. The operator's position must be ergonomic and safe as well as needing to be easy to get started with. That is why we have created a number of alternative operator's positions.

The first thing to choose is whether the operator's position should be open or provided with a cab. Depending on the size of the crane, the work being carried out and the truck, the open operator's position can be mid-mounted or alternatively to the right or left of the crane post.

The cab is left-mounted as standard, but can also be ordered right-mounted. Although the cab provides the best comfort and weather protection, it is possible to complement the open operator's position with both a crane canopy and a heated seat pad for a good operator environment.

There are several lever options. There are different options on joysticks and levers for both electrically controlled and mechanically controlled cranes.



Open operator's position with several options.

Flexibility is great. The open operator's position is available with either mechanical or electrical control. The seat can be placed to the right or left of the post and also centre mounted.

The steps are sturdy and non-slip, the handrails and handles make for a safe climb. For the best comfort, the open position can be supplemented with a heated seat pad and weather protection that shield against rain, driving snow and bright sunlight. The seat's armrests can be folded away and additional lighting can be chosen on the outer boom and around the operator's position.

Joystick and levers

There are several lever options. There are different options on joysticks and levers for both electrically controlled and mechanically controlled cranes.

Operator's cab

Our cab offers the very best comfort and driving experience. It is a modern and ergonomic solution that creates a comfortable, protected and safe operator environment in all weather and climatic conditions. Thanks to the quick height-adjustable cab, visibility can be optimally adjusted.

Clarity and comfort

The cab has a comfortable, ergonomic operator's position and well-positioned controls. The cab can be equipped with mechanical control or electrical control.



+ Entertainment

The cab can be equipped with a radio package (DAB and FM) including USB and AUX sockets as well as two speakers.

+ Lighting

Ceiling mounted LED lighting ramp 120W, 8800 lumens and rear LED lamp respectively can be chosen as an option.

+ Heating and cooling

Water heaters, Eberspracher D2 diesel heater and A/C Waeco coolair RT880 are three options that increase comfort.

+ Colour scheme

The cab can be ordered in your own choice of colour, based on RAL codes.

+ Engine control

Special engine control can be selected to control start, stop and rpm adjustment

OPTIONS & FEATURES

That your truck crane lives up to your expectations is important to us. Together, we tailor the perfect solution to suit your specific needs.

Our cranes have a high standard level right from the start. But there are still opportunities to equip the crane a little extra so you get it the way you want it.

CONTROL SYSTEM AND LEVERS

For electrical control of Cranab cranes with cab, we offer two good joystick options. Parkers mini-lever is standard and a trigger lever is optional. The trigger lever consists of a Parker base and a joystick with a pistol grip for thumb and index finger. It is also adapted for future functions.

For many truck crane operators, a longer joystick is particularly sought after because it is perceived to provide a better level of comfort, especially in a

crane-post mounted cab where movements and vibrations are more tangible than otherwise.

COLOUR DISPLAY

If you choose an electrically operated crane and driver's cab, a clear LCD screen shows the crane settings, among other things.

WEIGHING SYSTEM

An option for Cranab's truck cranes are weighing solutions. With a crane weighing device, the vehicle can be fully loaded without the risk of exceeding the permissible weight limits. Each load can be optimised and productivity increased, avoiding unnecessary trips. The operator can feel safe and the vehicle will be roadworthy.

” The crane has a good lifting geometry. We load and unload many times in a day, and geometry provides good continuity in that work process.

Micke Andersson | EHAB Åkeri



Support leg valve
Electrically/manually operated. 4-6-8 sections adapted to 1-circuit, 2-circuit and LS systems.



Retraction of support legs
180 degree support leg retraction with external hose routing or mechanical retraction 45 or 60 degrees.

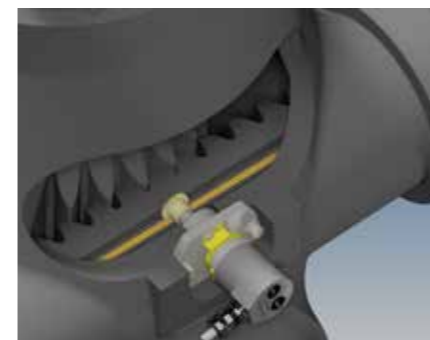

Lighting
LED lights on front of outer boom and operator's position. Also available directed to the rear. Illuminates the entire working area. More options are available.



Slew sensor
The slewing motor is equipped with a sensor for slew position. Applies to recycling cranes.

Control more than the crane
Start and stop the truck's engine, as well as regulate the rpm.

Weighing function
One of the most important options for Cranab's truck cranes is the scales. They help the operator load the truck correctly to make sure that it is neither overloaded nor underloaded.



Activation lock
Safety device when operating the stabiliser leg valve.



Colour options
The standard colour is red, but the lifting arm and rocker arm can be ordered in any colour as an option.



OVERVIEW CRANES



TL12								LS	1K	2K	Weight	Telescope
TL12.1	8,3	115 kNm	8,3 m	1,57 m	425°	29,3	26	120-160	80-100	2 x 70	2415 kg*	Single
TL12.2	10,0	106,4 kNm	10,0 m	3,1 m	425°	29,3	26	120-160	80-100	2 x 70	2535 kg*	Double

TZ12									1K	2K	Weight	Telescope
TZ12.2	7,7	110,5 kNm	7,7 m	2,53 m	425°	29,3	26	120-160	80-100	2 x 70	2450 kg*	Double
TZ12.1	8,3	108 kNm	8,3 m	1,97 m	425°	29,3	26	120-160	80-100	2 x 70	2425 kg*	Single
TZ12.2	9,3	102,8 kNm	9,3 m	3,1 m	425°	29,3	26	120-160	80-100	2 x 70	2475 kg*	Double
TZ12.2	10,5	99,7 kNm	10,5 m	3,9 m	425°	29,3	26	120-160	80-100	2 x 70	2515 kg*	Double

TZ18								LS	1K	2K	Weight	Telescope
TZ18.1	8,3	182 kNm	8,3 m	1,85 m	425°	29,3	26	120-160	80-100	2 x 70	2910 kg*	Single
TZ18.2	10,2	171 kNm	10,15 m	3,70 m	425°	29,3	26	120-160	80-100	2 x 70	3000 kg*	Double

RZ12									1K	2K	Weight	Telescope
RZ12.2	7,7	110,5 kNm	7,7 m	2,53 m	425°	29,3	26	120-160	80-100	2 x 70	2450 kg*	Double
RZ12.1	8,3	108 kNm	8,3 m	1,97 m	425°	29,3	26	120-160	80-100	2 x 70	2425 kg*	Single
RZ12.2	9,3	102,8 kNm	9,3 m	3,1 m	425°	29,3	26	120-160	80-100	2 x 70	2475 kg*	Double
RZ12.1	10,5	99,7 kNm	10,5 m	3,9 m	425°	29,3	26	120-160	80-100	2 x 70	2515 kg*	Double

RZ18								LS	1K	2K	Weight	Telescope
RZ18.1	8,4	182 kNm	8,3 m	1,85 m	425°	29,3	26	120-160	80-100	2 x 70	2910 kg*	Single
RZ18R	8,4	172 kNm	8,3 m	1,85 m	425°	29,3	26	120-160	80-100	2 x 70	2850 kg*	Double
RZ18.2	10,2	171 kNm	10,15 m	3,70 m	425°	29,3	26	120-160	80-100	2 x 70	3000 kg*	Double

* = Weight with open operator's position.

LIFTING FORCE* FOR RESPECTIVE REACH

TL12		2,0	3,0 m	4,0 m	5,0 m	6,0 m	7,0 m	8,0 m	9,0 m	10,0 m
TL12.1	8,3		3500 kg	2900 kg	2320 kg	1940 kg	1630 kg	1380 kg		
TL12.2	10,0		3300 kg	2600 kg	2100 kg	1810 kg	1500 kg	1300 kg	1130 kg	970 kg

TZ12		2,0 m	3,0 m	4,0 m	5,0 m	6,0 m	7,0 m	8,0 m	9,0 m	10,0 m
TZ12.2	7,7	4500 kg	3200 kg	2570 kg	2200 kg	1830 kg	1530 kg			
TZ12.1	8,3		3090 kg	2390 kg	2005 kg	1750 kg	1510 kg	1300 kg		
TZ12.2	9,3		3080 kg	2380 kg	1930 kg	1730 kg	1470 kg	1260 kg	1100 kg	
TZ12.2	10,5		2880 kg	2250 kg	1870 kg	1650 kg	1430 kg	1230 kg	1050 kg	900 kg

TZ18		2,0 m	3,0 m	4,0 m	5,0 m	6,0 m	7,0 m	8,0 m	9,0 m	10,0 m
TZ18.1	8,3					3100 kg	2500 kg	2250 kg		
TZ18.2	10,2					2900 kg	2400 kg	2100 kg	1850 kg	1650 kg

RZ12		2,0 m	3,0 m	4,0 m	5,0 m	6,0 m	7,0 m	8,0 m	9,0 m	10,0 m
RZ12.2	7,7	4500 kg	3200 kg	2570 kg	2200 kg	1830 kg	1530 kg			
RZ12.1	8,3		3090 kg	2390 kg	2005 kg	1750 kg	1510 kg	1300 kg		
RZ12.2	9,3		3080 kg	2380 kg	1930 kg	1730 kg	1470 kg	1260 kg	1100 kg	
RZ12.1	10,5		2880 kg	2250 kg	1870 kg	1650 kg	1430 kg	1230 kg	1050 kg	900 kg

RZ18		2,0 m	3,0 m	4,0 m	5,0 m	6,0 m	7,0 m	8,0 m	9,0 m	10,0 m
RZ18.1	8,4					3100 kg	2500 kg	2250 kg		
RZ18R	8,4		5400 kg	4100 kg	3500 kg	2900 kg	2500 kg	2200 kg		
RZ18.2	10,2					2900 kg	2400 kg	2100 kg	1850 kg	1650 kg

* applies to unequipped crane without e.g. grapple and rotator

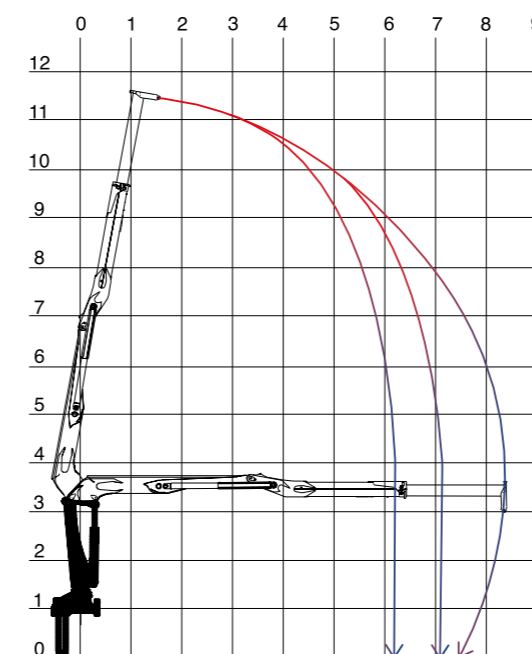

Principle sketch of how lifting force is affected by the extension.

DIMENSIONS TL12

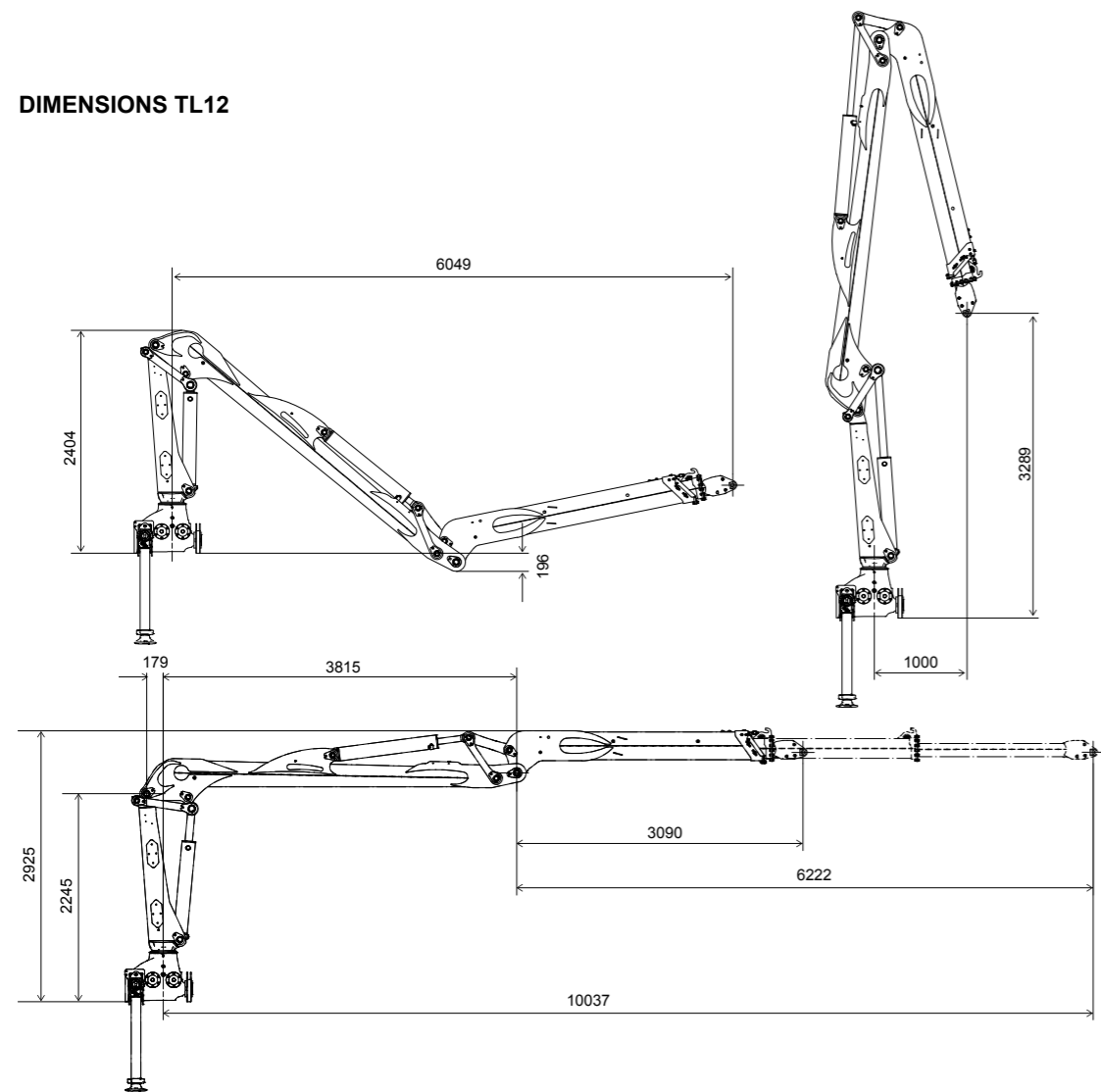

WEIGHT AND STABILITY TL12

Weight

TL12	A (kg)	B (m)	C (kg)	D (m)	E (kg)	F (m)	G (m)
TL12.1	1060	10,0	1020	3,865	900	0	0,1
TL12.2	1380	8,3	900	3,429	900	0	0,1

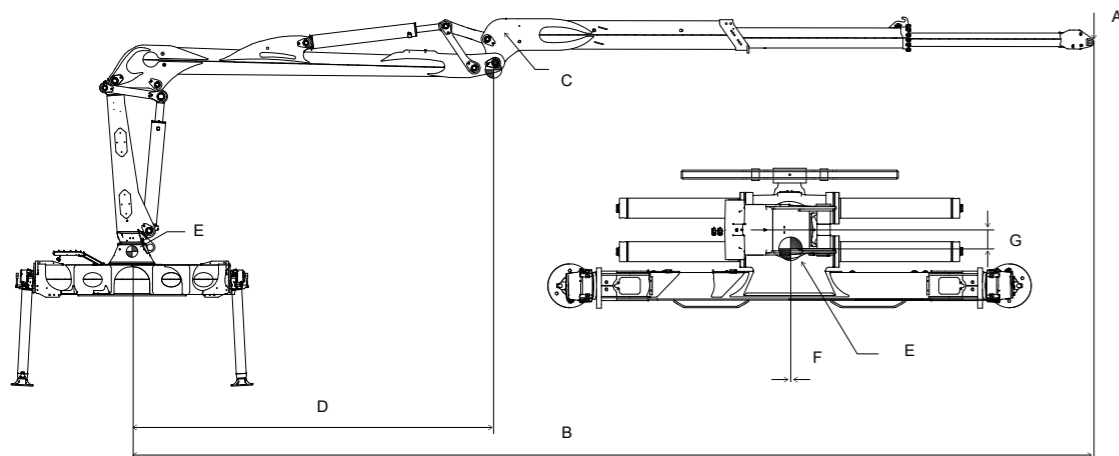

DIMENSIONS TZ12 & RZ12

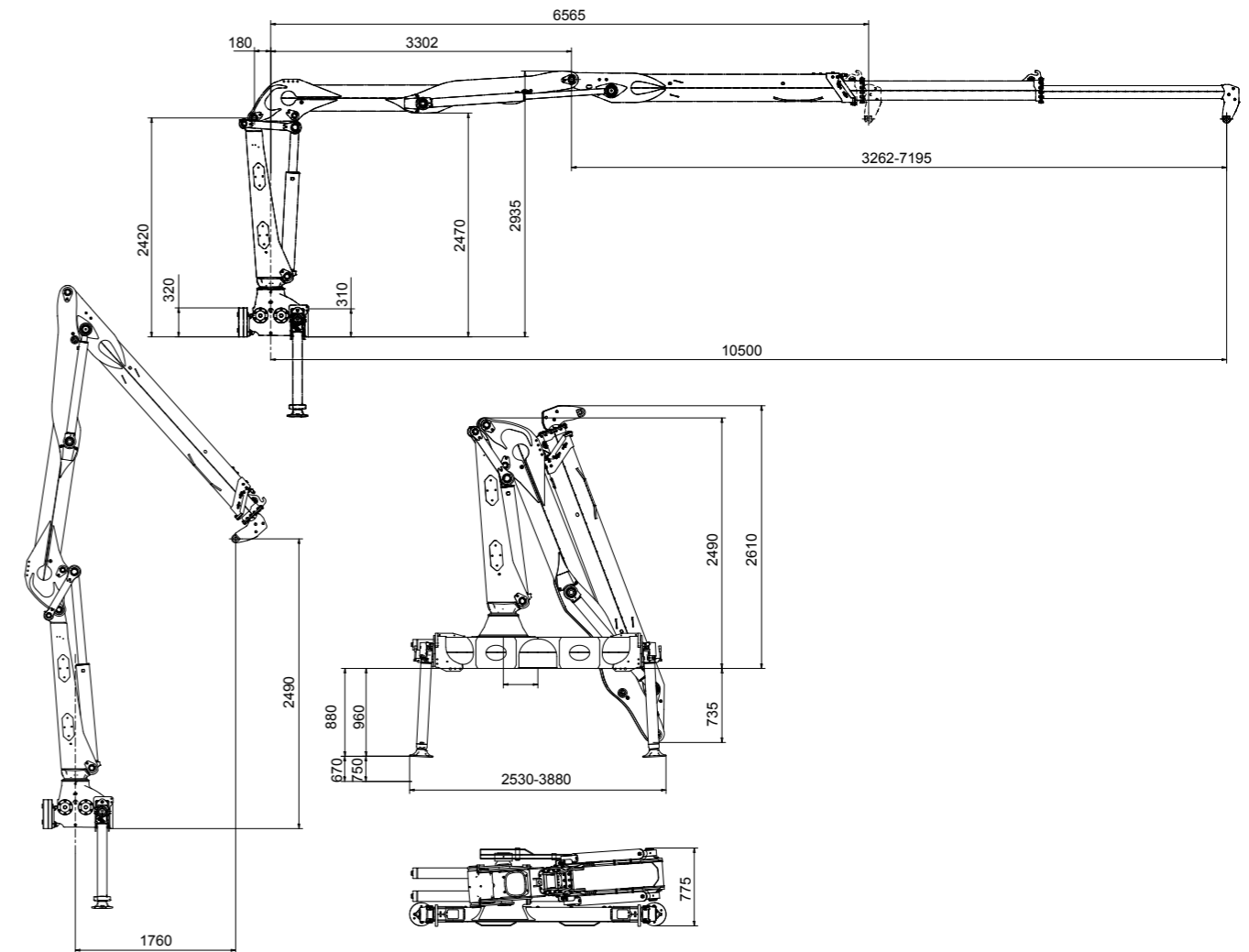

Because we continuously work with product development and continuous improvement, we reserve the right to adjust data in the brochure.

We are not responsible for any typos. If you need additional information or design documentation, please contact us at Cranab.

DIMENSIONS TZ18.1 / TZ18.2 | RZ18.1 / RZ18.2

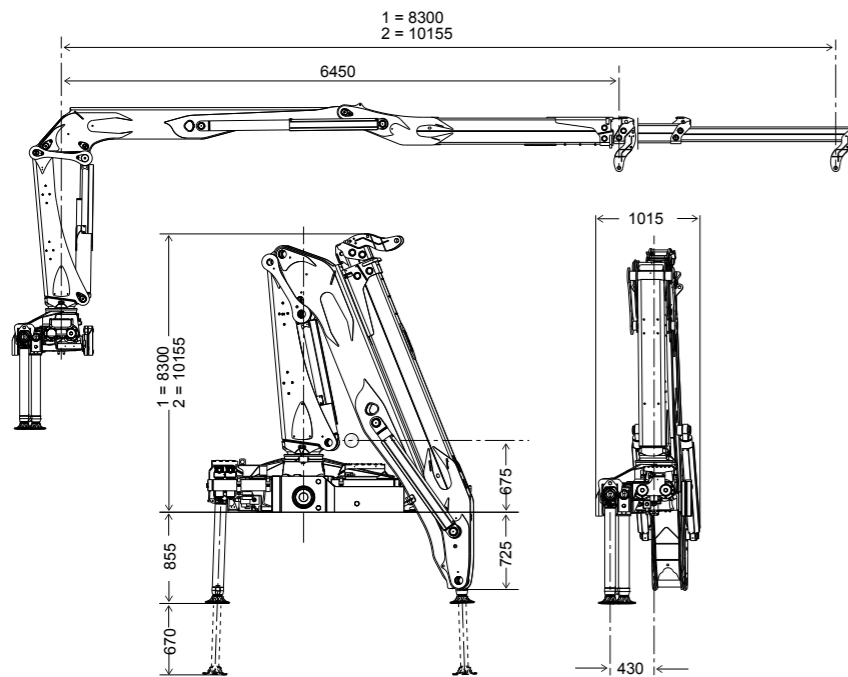

DIMENSIONS RZ18R

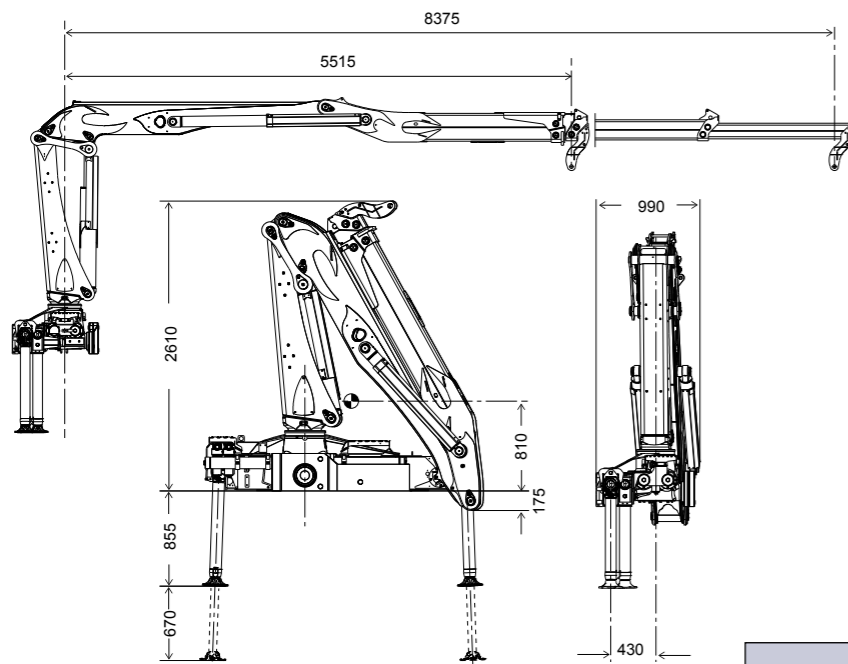

Because we continuously work with product development and continuous improvement, we reserve the right to adjust data in the brochure.

We are not responsible for any typos. If you need additional information or design documentation, please contact us at Cranab.

These illustrations show a selection of positions, but of course the crane and pillars are also available in other positions.

OPERATOR'S POSITION - OPEN | LEFT & RIGHT MOUNTED

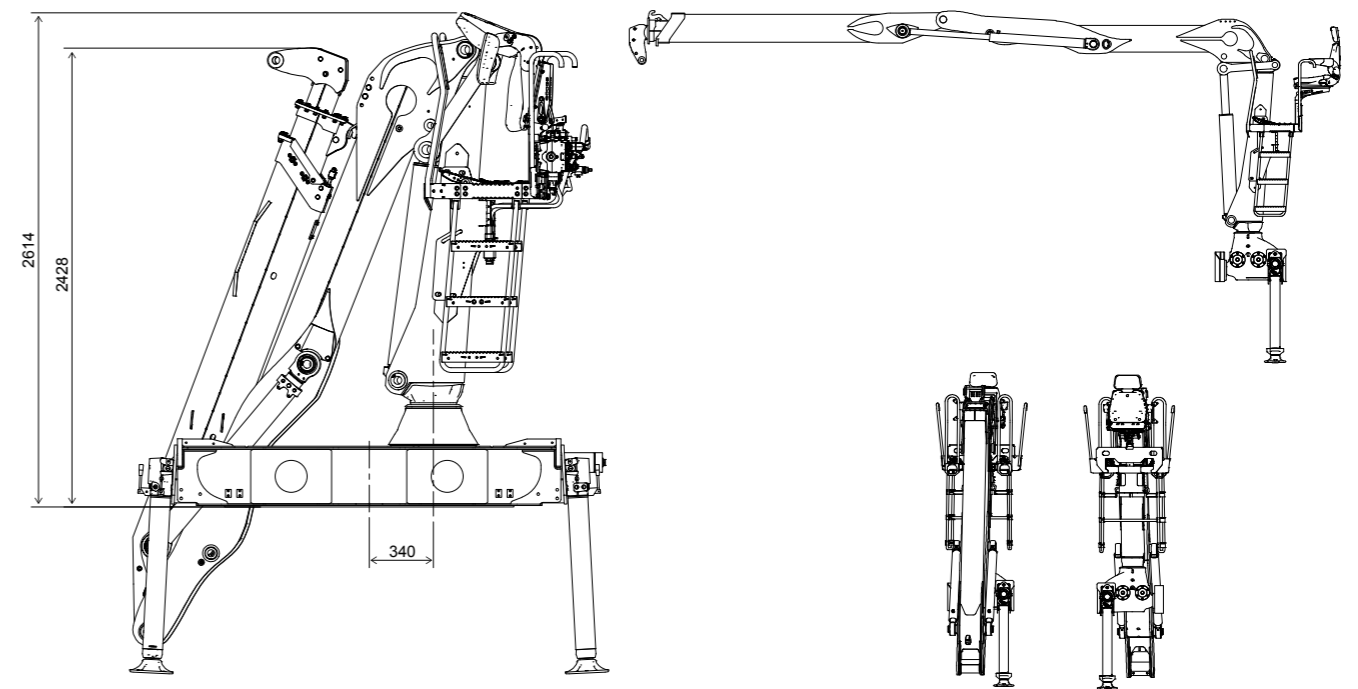

CAB

ROTATION VOLUME

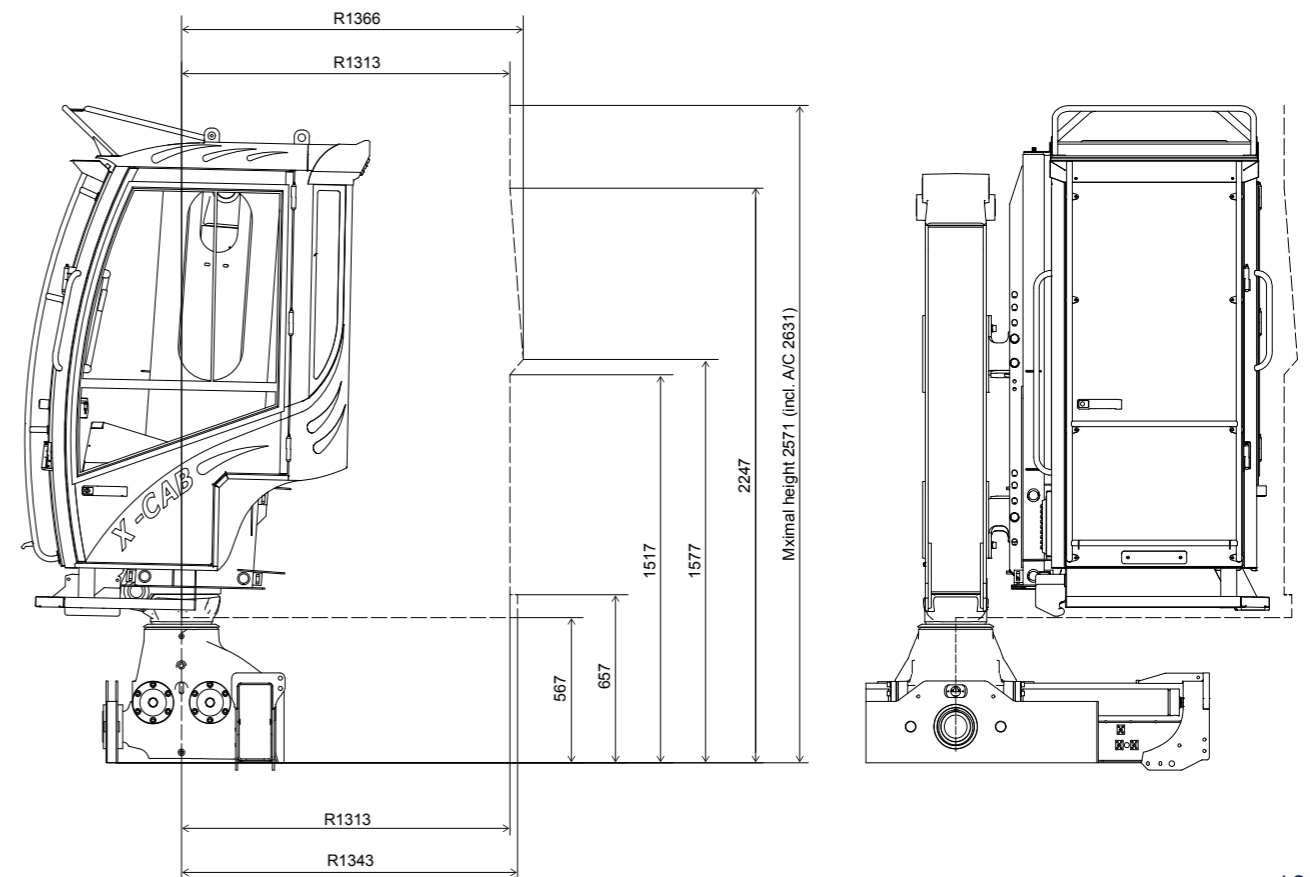

Experience. Technology. Innovation.

Cranab's factories are located in Vindeln, deep in the forests of West Bothnia in Sweden. Here we develop and manufacture world-class cranes, grapples and land clearing machines. We are driven by a genuine passion for forestry and road clearance technology. We are also driven by our unyielding goal to constantly push technology development forwards. Although we are based in northern Sweden, we reach out to the whole world, close to the customers we develop products for. We listen carefully to their requirements and draw on more than 60 years of experience and solid technological expertise to develop innovative products.

Experience, technological expertise and an unswerving determination to improve. This is a somewhat ingenious combination if you ask us.

Cranab Slagkraft is part of the CRANAB GROUP, which also includes Vimek. Today, the companies are world-leaders in their respective fields. Our common success factors are the development, manufacture and marketing of the best technical solutions for modern forestry and road clearance work.



FASSI GROUP